



NATIONAL JUNIOR COLLEGE
SENIOR HIGH 2
Higher 2

NAME

CLASS

REGISTRATION NUMBER

MATHEMATICS

9758

Preliminary Examination

30 August 2022

Paper 1

3 hours

Candidates answer on the Question Paper.

Additional Materials: List of Formulae (MF26)

READ THESE INSTRUCTIONS FIRST

Write your name, class and registration number in the boxes above.
Please write clearly and use capital letters.

Write in dark blue or black pen.
You may use an HB pencil for any diagrams or graphs.
Do not use paper clips, glue or correction fluid.

Answer **all** the questions.
Write your answers in the spaces provided in the question paper.
Give non-exact numerical answers correct to 3 significant figures, or 1 decimal place in the case of angles in degrees, unless a different level of accuracy is specified in the question.
The use of an approved graphing and/or scientific calculator is expected, where appropriate.
All relevant working, statements and reasons must be shown in order to obtain full credit for your solution.

You are reminded of the need for clear presentation in your answers.
Up to 2 marks may be deducted for improper presentation.

The number of marks is given in the brackets [] at the end of each question or part question.
The total number of marks for this paper is 100.

Question Number	Marks Possible	Marks Obtained
1	5	
2	6	
3	6	
4	7	
5	7	
6	8	
7	8	
8	9	
9	9	
10	10	
11	12	
12	13	
Presentation Deduction		- 1 / - 2
TOTAL	100	

- 1 (i) Given that $I_n = \int_1^e x(\ln x)^n dx$ for $n \in \mathbb{Z}$, $n \geq 0$, show that

$$I_n = \frac{e^2}{2} - \frac{n}{2} I_{n-1}$$

for all $n \in \mathbb{Z}^+$. [2]

- (ii) Find the exact volume of the solid generated when the region bounded by the curve $y = \sqrt{x} \ln x$, the x -axis and the line $x = e$ is rotated completely about the x -axis. [3]

- 2 In this question, p is a constant such that $p > 1$.

- (i) Using an algebraic method, solve $\frac{px^2 - 1}{x^2 + (1-p)x - p} \geq 1$. Express your answer in terms of p . [4]

- (ii) Hence, or otherwise, solve $\frac{px^2 - 1}{x^2 + (p-1)|x| - p} \geq 1$. [2]

- 3 Relative to the origin O , points A , B and C have position vectors \mathbf{a} , \mathbf{b} and $3\mathbf{a} - 4\mathbf{b}$ respectively, where \mathbf{a} and \mathbf{b} are non-zero and non-parallel.

- (i) Given that OAB is an equilateral triangle, show that $\mathbf{a} \cdot \mathbf{b} = k|\mathbf{a}|^2$, where k is a constant to be determined. [2]

- (ii) Deduce whether OA and AC are perpendicular. [2]

- (iii) Interpret geometrically the vector equation $\mathbf{r} \times (\mathbf{b} - \mathbf{a}) = \mathbf{a} \times (\mathbf{b} - \mathbf{a})$. [2]

- 4 (i) Two complex numbers w and u satisfy the equations

$$w^* - 2iu = 8 \quad \text{and} \quad (2i - 1)w + 2u^* = 4.$$

Find w and u , giving your answers in the form $x + iy$, where x and y are real. [4]

- (ii) Given that both w and u are roots of the equation $(z^2 - 4z + c)(z^2 - dz + 10) = 0$, find the values of the real numbers c and d . [3]

5

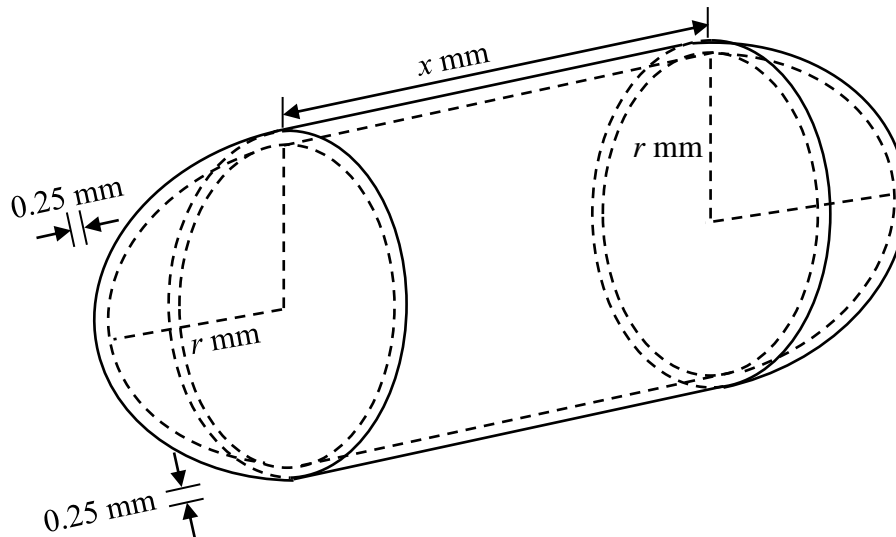

The diagram above shows a capsule consisting of two identical hollow hemispherical caps at the two ends and a hollow cylindrical body in the middle. It has a capacity of 600 mm^3 to contain medicinal substance, which is surrounded by a hard gelatin shell that has a thickness of 0.25 mm . The internal radius and internal length of the cylindrical body are $r \text{ mm}$ and $x \text{ mm}$ respectively. The internal radius of each hemispherical cap is $r \text{ mm}$. The volume of gelatin used in making the hard shell is $V \text{ mm}^3$.

(i) Show that $V = \left(r + \frac{1}{4}\right)^2 \left(\frac{\pi}{3} + \frac{600}{r^2}\right) - 600$. [3]

(ii) Using differentiation, find the value of r that would result in the least amount of gelatin used to make the hard shell. [4]

6 (i) By considering $u_k - u_{k+1}$, where $u_k = \frac{1}{k!}$, find

$$\frac{3}{4!} + \frac{4}{5!} + \frac{5}{6!} + \cdots + \frac{3n+2}{(3n+3)!}$$

in terms of n . [4]

(ii) Find $\sum_{r=5}^{3n+3} \frac{r-1}{r!}$. Hence show that $\sum_{r=5}^{3n+3} \frac{3}{r!} < \frac{1}{24}$. [4]

- 7 Amy cuts off pieces of ribbon from a long roll of ribbon. The first piece of ribbon she cuts off is 160 cm long and each successive piece is 8 cm shorter than the preceding piece.

(a) What is the maximum number of pieces of ribbon that Amy can cut off? [2]

After Amy has cut off the number of pieces found in part (a), her friend, Bala, continues to cut off more pieces from the same remaining long roll of ribbon, such that the first piece is 160 cm long and each successive piece is p times as long as the preceding piece, where p is a constant such that $0 < p < 1$.

(b) Given that the total length of ribbon that Bala cuts off can never be greater than 10 m regardless of the number of pieces he cuts off, find the largest value of p . Taking p to be this value and by solving an appropriate inequality, find the maximum number of pieces that can be cut off before the total length of ribbon that Bala cuts off exceeds 9.5 m. [4]

(c) After Amy has cut off the number of pieces found in part (a) and Bala has cut off the number of pieces found in part (b), there is 4.5 cm of ribbon left in the roll of ribbon. Determine the length of the original long roll of ribbon, leaving your answer to the nearest cm. [2]

- 8 Two complex numbers are $z = 2\left(\cos\frac{\pi}{4} - i\sin\frac{\pi}{4}\right)$ and $w = (-i\sqrt{3})z$.

(i) Show that $z + w^* = re^{i\left(\frac{3\pi}{4}\right)}$ for some positive constant r to be determined exactly. [3]

(ii) Hence find the values of n such that $(z + w^*)^n$ is purely imaginary. [2]

It is given that $v = \frac{z + w^*}{z^* w}$.

(iii) By finding $\arg(v)$ or otherwise, find an equation relating $\operatorname{Re}(v)$ and $\operatorname{Im}(v)$. Also, find $|v|$ exactly. [4]

- 9 The graph of $y = f(x)$ has two stationary points at $(2, -2)$ and $(4, 2)$ and intersects the x -axis at $x = 1$, $x = 3$ and $x = 5$ as shown in the diagram below. There is a vertical asymptote $x = 0$ and a horizontal asymptote $y = -4$.

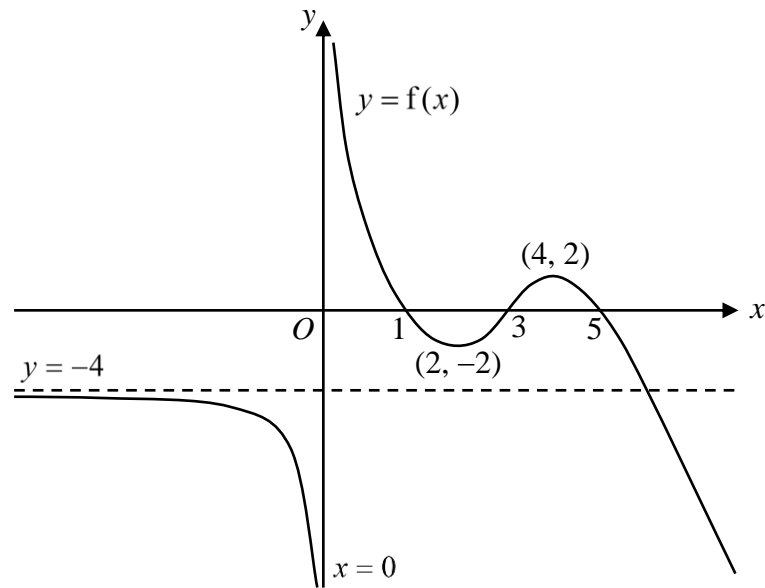

On separate clearly labeled diagrams, sketch the following graphs. Label clearly, where possible, the asymptotes, stationary points and points of intersection of the curves with the axes in your diagrams.

(a) $y = \frac{1}{f(x)}$ [4]

(b) $y = -f'(x)$ [3]

The curve Q has parametric equations $x = t + 4$ and $y = pt^2 + q$, where p and q are real positive constants. State a cartesian equation of Q and the range of possible values of q such that the curve Q meets the curve $y = f(x)$ exactly once. [2]

- 10** It is given that $f(x) = (a+x)^n$, where a and n are non-zero real constants such that $a > 0$, and x is non-zero. The first, third and fifth terms in the Maclaurin series of $f(x)$ are the first, second and third terms of an infinite geometric series G respectively.

(i) Find the possible values of n , showing all working clearly. [4]

Assume instead for the remainder of this question that $n = -1$.

(ii) Show that the range of values of x for the Maclaurin series of $f(x)$ to converge is equal to the range of values of x for G to converge. [2]

In the case where G converges, the sum to infinity of G is denoted by S .

(iii) Find S in terms of a and x . [2]

(iv) Find, in terms of a , the range of values of S as x varies. Show your working clearly. [2]

11

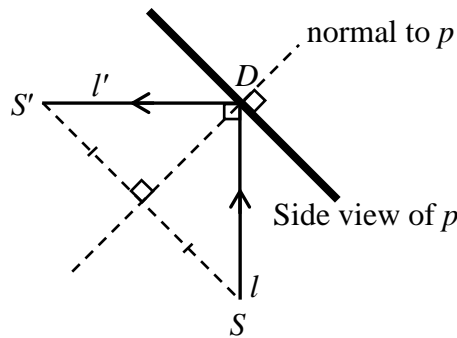

The diagram above shows a glass prism. The surface of the prism is part of the plane p with equation $by - z = 4$, where b is an integer constant. A ray of light l passes through a point S with coordinates $(5, 1, 3)$, and travels in a direction parallel to the unit vector $\frac{2}{3}\mathbf{i} + c\mathbf{j} + \frac{2}{3}\mathbf{k}$, where c is a negative constant, until it hits the surface of the prism at point D . The light ray is reflected by the surface of the prism. The reflected ray of light, l' , passes through the point S' , where S' is the image of point S . It is given that the lines l and l' are perpendicular and they lie on the same plane as the normal to p passing through point D . Also, the acute angle between l and the normal to p is equal to the acute angle between l' and the normal to p .

(i) Find the exact value of c and show that $b = 1$. [4]

(ii) Find the coordinates of point D . [3]

(iii) Show that the coordinates of S' are $(m, -1, 1)$ for some integer constant m to be determined and find a vector equation of l' in exact form. [5]

- 12 Water is flowing out from a conical funnel from its tip at the bottom. The top radius of the funnel is 0.5 m and the depth of the funnel is 1 m. The funnel is initially filled to the brim and no water is added to the funnel thereafter. The side view of the funnel and the water inside it are shown in the diagram below.

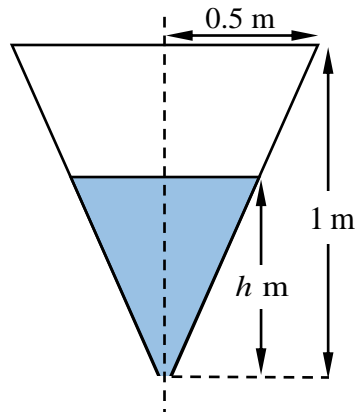

It can be assumed that the vertical length of the tip cut off at the bottom (to produce the funnel) is insignificant compared to the depth of the conical funnel. It is also known that the velocity $v \text{ ms}^{-1}$ of the water flowing out from the funnel at its tip can be modelled by *Torricelli's law*,

$$v^2 = 2gh,$$

where $g \text{ ms}^{-2}$ is the constant acceleration due to gravity and $h \text{ m}$ is the depth of the water in the cone at time $t \text{ s}$.

- (i) Express the volume $W \text{ m}^3$ of the water in the funnel at time $t \text{ s}$ in terms of h . [2]

It is given that the radius of the tip cut off at the bottom of the funnel is $a \text{ m}$. Also, it is known that the volume of water flowing out from the funnel per second is equal to the product of the cross-sectional area of the hole at the bottom of the funnel and the velocity $v \text{ ms}^{-1}$ of the water flowing out from the funnel.

- (ii) Use the above information and Torricelli's law to express $\frac{dW}{dt}$ in terms of a , g and h .

Hence, form a differential equation relating h and t . [4]

- (iii) Show that $h = \left[1 - (ka^2\sqrt{2g})t\right]^p$ for some rational constants k and p to be determined. [3]

- (iv) Find the time $T \text{ s}$ taken for the funnel to become empty. Express your answer in terms of a and g . [2]

- (v) Sketch the graph of h against $\frac{t}{T}$. [2]